

CAST STAINLESS STEEL

XCESX ENCLOSURES

EXPLOSIONPROOF / FLAMEPROOF

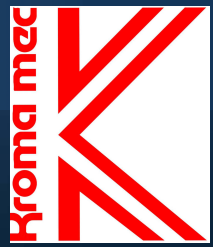

BUILT TO LAST IN HIGHLY CORROSIVE AREAS

FEATURES

- 5 standard sizes available
 - Flat plate cover design
- Corrosion resistant, cast stainless steel 316L
 - Stainless steel hinge kit
- Pre-drilled for mounting panel (mounting panel optional)
 - Type 4 watertight gasket
 - Stainless steel cover bolts
- Internal / external grounding screws
 - Removable lifting eye bolts
- Lid-lifter cover alignment device
 - Cast-on mounting lugs / feet
- Rated for Division I and Zone I Hazardous Areas
 - UL, cUL, ATEX, and IECEx Certifications



CAST STAINLESS STEEL

XCESX ENCLOSURES

DIVISION 1, ZONE 1

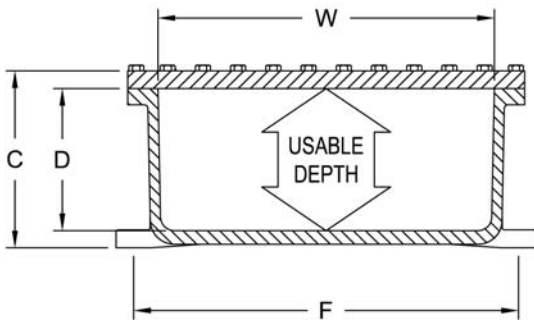
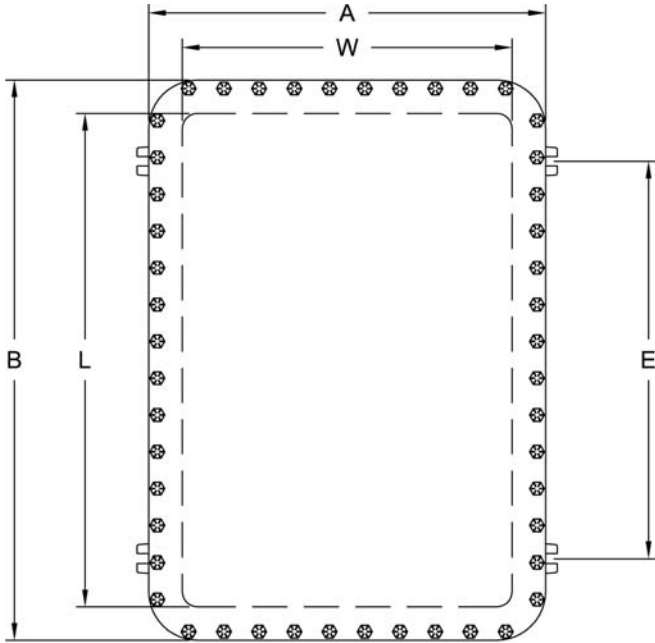

DESIGN OPTIONS

- Stainless steel cover bolts for Type 4X additional corrosion protection
 - Conduit (NPT & metric) and device (NPSM) drilling & tapping
 - Auxiliary devices such as breather / drains and flame arrestors
- Custom machining - milling, counter-boring, spot-facing, blind drilled holes, entries, chamfers
 - Round or square windows
- Operating devices: pushbuttons, pilot lights, selector switches

ENCLOSURE MATERIAL

- Enclosure - stainless steel 316L
- Cover bolts - stainless steel 316L
- Hinge Kits - stainless steel 316L

CERTIFICATIONS

Class I, Division I Group B, C & D
 Class II, Groups E, F & G
 Class III
 Class I, Zone 1, AEx d IIB
 Type 4X
 IECEx
 IECEx Ex d IIB Gb

IECEx Ex tD A2I IP66
 ATEX
 II 2 G Ex d IIB
 II 2 D Ex tD A2I IP66



XCESX Catalog #	Usable Depth	Inside Nom. Dimensions			Overall Dimensions			Mounting Lug CL to CL		Mtg. Bolt Size	Ship Weight	Pan Catalog #			Pan. Dimensions		Steel Pan Weight	Hinge Cat #
		W	L	D	A	B	C	E	F			Steel	Alum.	Phen.	W	H		
101408	8	10	14	8	13-9/16	17-7/16	9-7/8	10-7/8	13	7/16	195	XSM1014	XSA1014	XSB1014	8-7/8	12-7/8	3-1/2	XHBK-2
121208	8	12	12	8	16-1/4	16-1/4	9-7/8	8-5/8	15-3/4	5/8	210	XSM1212	XSA1212	XSB1212	10-7/8	10-7/8	3-3/4	XHCK-2
122410	10	12	24	10	16-1/4	28-1/4	11-3/4	18-3/8	15-3/4	5/8	380	XSM1224	XSA1224	XSB1224	11	23	8	XHCK-2
242410	10	24	24	10	28-7/8	28-7/8	12-3/8	18-3/8	28	3/4	735	XSM2424	XSA2424	XSB2424	22	22	15-1/4	XHFK-2
243610	10	24	36	10	28-7/8	40-7/8	12-3/8	29	28	3/4	985	XSM2436	XSA2436	XSB2436	34	22	23-1/2	XHFK-3